

WARRANTY INFORMATION

Meter-Treater, Inc. (M-Ti) warrants to its customers that the hardware products that M-Ti manufactures and sells will be free from defects in material and workmanship. Warranty coverage is for ten (10) years starting from the date of installation, but no longer than eleven (11) years from the date of the original shipment from M-Ti. If any such product proves defective during the applicable warranty period, M-Ti, at its discretion, will repair without charge for parts and labor or will provide a replacement in exchange for the defective product.

This warranty shall not apply to any defect, failure, and/or damage caused by improper use, or inadequate maintenance or care. M-Ti shall not be obligated to furnish service under this warranty (a) to repair damage resulting from connection to incompatible equipment; or (b) to service a product that has been modified, altered or integrated with other products.

For additional coverage information, please see "A Ten Year Surge Suppressor 'Limited' Warranty".

WARRANTY RETURNS

All warranty and non-warranty repairs must be returned freight prepaid and insured to **MTI**. All returns must have a Return Materials Authorization (RMA) number on the outside of the shipping container. This number may be obtained from **MTI** Customer Service at (800) 342-6890.

Products returned without an RMA number will not be accepted.

NOTE

IF UNIT(S) ARE RECEIVED DAMAGED, NOTIFY THE SHIPPING COMPANY IMMEDIATELY. RETAIN ALL SHIPPING CONTAINERS AND PACKING MATERIALS FOR INSPECTION.

Meter-Treater, Inc.
1349 South Killian Drive, Lake Park, Florida 33403
Phone: (561) 845-2007 Fax: (561) 848-2372
E-mail: sales@metertreater.com
Website: www.metertreater.com

BPT Series Surge Protective Device



**SURGE PROTECTIVE DEVICES
FOR
AC POWER APPLICATIONS**

COMMERCIAL INSTALLATIONS

**USER MANUAL
AND
INSTALLATION GUIDE**

P/N: 906-4000-000
MS-197-04/22/09

GENERAL

- A) This document provides detailed information on how to install and operate the **BPT Series** of Surge Protective Devices (SPD).
- B) Units should be mounted as close as possible to the AC panel to be protected. It is recommended that conduit, preferably metallic, be utilized to accomplish this connection.
- C) The **BPT Series** of Protectors are installed and connected in parallel ("shunt") across the AC supply to be protected. Connecting wires do not carry the supply current, only the short duration currents associated with the suppression of a transient event.
- D) Identified or indicated terminals must be connected exactly with respect to the AC Power feeding the SPD. Failure to do so may result in damage to the device or pose a danger to personnel.
- E) Incorrect installation may significantly impair the performance of the Surge Protective Device. It is particularly important that all installation procedures and guidelines be followed exactly.
- F) INSTALLATION OF THIS DEVICE SHOULD ONLY BE PERFORMED BY A QUALIFIED LICENSED ELECTRICIAN.**
- G) Before starting any installation procedures, verify service voltages with an AC voltmeter to ensure that the correct SPD model has been selected.
- H) DO NOT CONNECT WITHOUT SECURING POWER FROM THE DISTRIBUTION PANEL.
- I) CHECK TO ENSURE THAT ALL CONNECTIONS ARE CORRECT AND SECURE BEFORE ENERGIZING.
- J) KEEP THIS MANUAL IN A SAFE DRY PLACE FOR FUTURE REFERENCE.

FOR SERVICE

CONTACT MTI CUSTOMER SERVICE AT (800) 638-3788

**MOUNTING INFORMATION
(ALL BPT MODELS)**

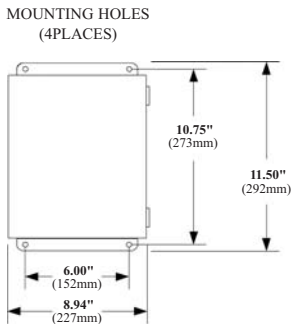

[Figure #1: BPT Front View]

After determining a position to mount the device, that will minimize the length of the connecting wires, drill a hole in the BPT for the conduit to run the wires from the distribution panel to the connecting lugs inside the SPD. Installation is simplified if the wires enter the enclosure at the top (see figure #2) of the enclosure. Securely mount the TVSS unit using 1/4-20 bolts in the four (4) mounting holes provided in the enclosure's mounting flanges.

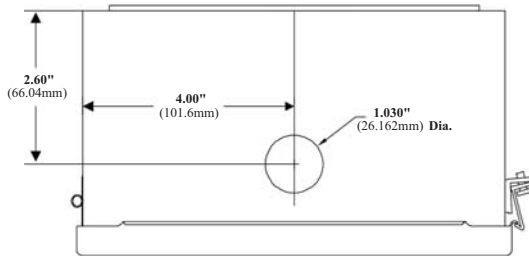

[Figure #2: BPT Top View]

CONSTRUCTION
 14 gauge steel with continuous hinge:
 UL 50 Type 12 and Type 13
 NEMA/EEMAC Type 12 and Type 13
 JIC standard EGP-1-1967
 CSA Type 12
 IEC 529,IP65

FINISH
 ANSI 61 gray polyester powder coating
 inside and out over phosphatized surfaces.

MAINTENANCE INSTRUCTIONS

At intervals not to exceed two (2) months check and verify:

- 1. Diagnostic and Indication display.
- 2. Alarm Operation
- 3. Condition of ALL Connection Cables and Terminations

INSTALLATION, SERVICE OR REMOVAL OF THIS DEVICE SHOULD ONLY BE PERFORMED BY A QUALIFIED LICENSED ELECTRICIAN.

ANY ALTERATIONS, TAMPERING, MISUSE OR UNAUTHORIZED REPAIRS OF THIS PRODUCT WILL VOID ITS ORIGINAL FACTORY WARRANTY.

IMPORTANT DATA

DATE PURCHASED: _____ **DATE INSTALLED:** _____

DEALER/DISTRIBUTOR'S NAME AND ADDRESS: _____

CONTACT(S): _____

PHONE #: _____ **FAX #:** _____

CONTRACTOR'S NAME AND ADDRESS: _____

PHONE #: _____ **FAX #:** _____

PRODUCT INFORMATION

MODEL #: _____ **SERIAL #:** _____

MANUFACTURED DATE: _____

DO NOT CONNECT WITHOUT SECURING POWER FROM THE DISTRIBUTION PANEL

TROUBLESHOOTING GUIDE

There is little or no troubleshooting required for this Series of products. However, there are situations where there could arise a scenario where the Front Panel Diagnostics does not operate as intended. In such a case follow these directions...

PROBLEM:

No Front Panel Diagnostics or improper operation:

Ensure that SPD unit is properly connected to the AC Service Panel and that all connections are secure.

Confirm that the breaker in the AC supply panel is in the ON position.

If problem still persists: **TURN OFF BREAKER**, Open the SPD door and verify that all **VISIBLE** cable connections are properly secured, no loose wires. **DO NOT** attempt to troubleshoot the device below the black insulator shield. Close the door and reset the breaker.

In the unlikely event that these measures have failed to correct the problem contact your dealer or the factory for additional information.

INTERNAL LAYOUT



[Figure #11]

Unit shown is with dry contact and surge counter option.

THERE ARE NO USER SERVICEABLE PARTS INSIDE MAIN HOUSING

BPT (100/200) Models:

The specific product you have in service may be configured for any one of the following kA ratings: (100=100kA/Phase) and (200=200kA/Phase)

AC Service(s):

120 or 240Vac, Single Phase	277/480Vac, 3 Phase Wye
120/240Vac, Split Phase	220/380Vac, 3 Phase Wye
240 or 480Vac, Three Phase Delta	230/400Vac, 3 Phase Wye
120/240Vac, Three Phase Delta (High Leg)	240/415Vac, 3 Phase Wye
120/208Vac, 3 Phase Wye	

The **BPT Series** of Products are Non-Modular and have no customer/user serviceable parts inside. In situations where Service is required please contact the factory or your local Dealer.

INSTALLATION INSTRUCTIONS

Before starting the installation, measure the Line voltage with an AC voltmeter to ensure the correct device has been selected for the current application. The MCOV (maximum continuous operating voltage) **Cannot** exceed the maximum limits for the following service voltages:

120VAC=150MCOV	240VAC=320MCOV
220VAC=320MCOV	277VAC=320MCOV
230VAC=320MCOV	480VAC=550MCOV

STANDARD ELECTRICAL CONFIGURATIONS

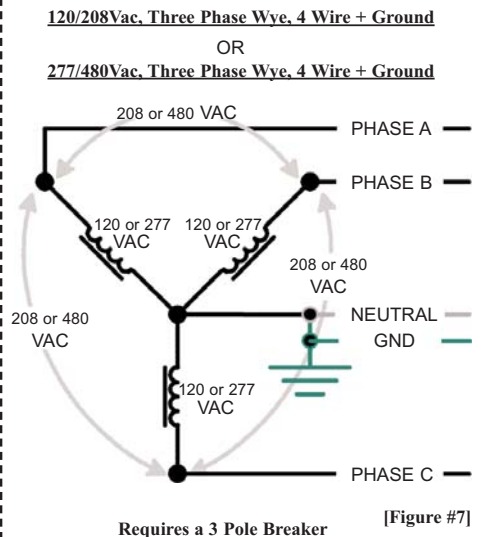
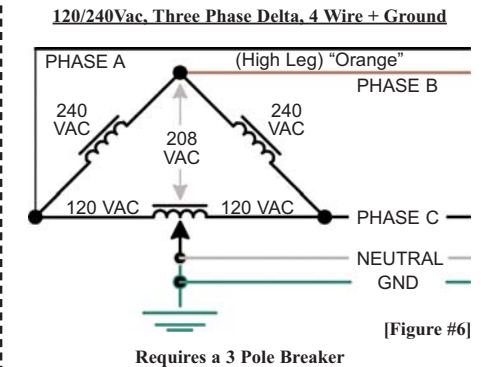
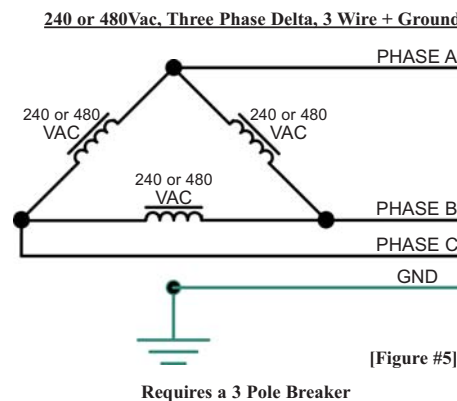
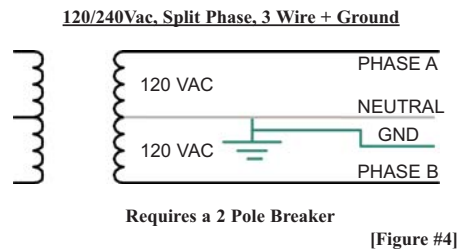
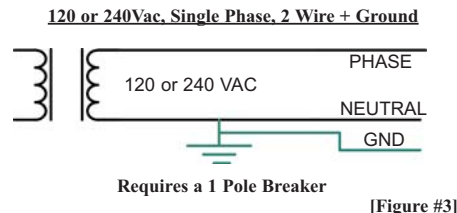

NOTE

Wye Configuration is applicable for:
220/380VAC
230/400VAC
240/415VAC

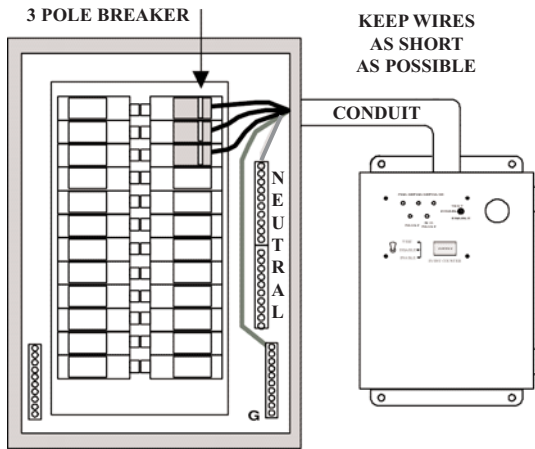

[Figure# 8: Three Phase Wye Configuration Shown]

The device shall be fed from a 30 Amp breaker, in accordance to the number of poles required.

Single Phase = 1 Pole Breaker
 Split Phase = 2 Pole Breaker
 Three Phase = 3 Pole Breaker
 Delta Units have no Neutral
 High Leg Delta = Phase "B" Orange

Because the SPD is installed in parallel or shunt with the load, VA rating is not limited.

1. CONNECT THE GROUND WIRE FROM THE SERVICE PANEL GROUND BUS TO THE LUG LABELED GROUND.
2. CONNECT THE NEUTRAL WIRE FROM THE SERVICE PANEL NEUTRAL BUS TO THE LUG LABELED NEUTRAL. (Except for Delta Applications)
3. CONNECT THE PHASE (HOT) WIRE(S) FROM THE BREAKER TO THE SPD DEVICE CONNECTORS LABELED PHASE "A", "B" AND "C", as required by application.

CAUTION

BEFORE ENERGIZING THE SPD:
 ENSURE ALL CONNECTIONS ARE CORRECT.
 DO NOT ENERGIZE WITH FRONT COVER OPEN.

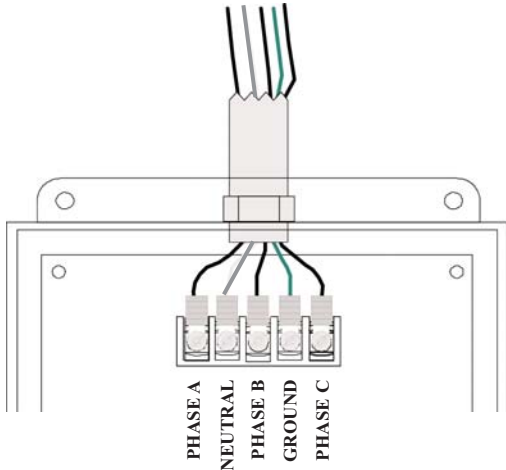

[Figure #9: Three Phase Wye Configuration Shown]

Attach and crimp (supplied) lug connectors to each # 8 or # 10 AWG wire, as required, before inserting it into the terminal block. Tighten the lug screws securely. Check all connections to ensure they are correct and properly secured.

NOTES:

- 1) For Single Phase Models, Phase "A" & Phase "C" lines are left vacant.
- 2) For Split Phase Models, Phase "B" is left vacant.
- 3) For Delta Configurations, the Neutral position is left vacant.

FRONT PANEL DIAGNOSTICS

OPERATION AND FEATURES

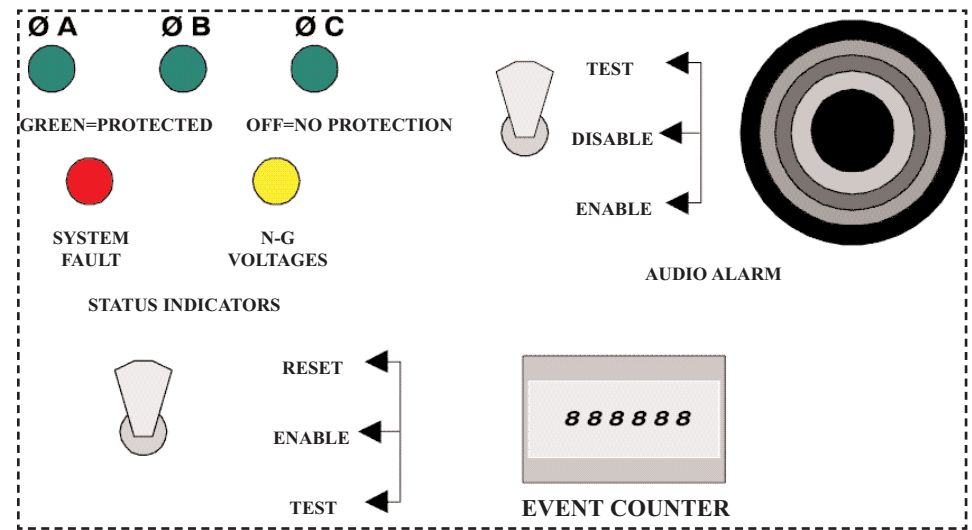

[Figure #10: Three Phase Wye Configuration Shown]

NOTES:

- | | | |
|--|---|---|
| <p>1) For Single Phase Models:
 Only 1 Green LED, in the Phase "B" position, is provided.</p> | <p>2) For Split Phase Models:
 2 Green LEDs, in Phase "A" & "C" positions, are provided.</p> | <p>3) For Delta Models:
 There is no Yellow, N-G, LED.</p> |
|--|---|---|

STATUS INDICATORS

GREEN LEDs: When the SPD is securely connected and operating properly, the GREEN LEDs, under the heading "PHASE INDICATORS", will be illuminated. No other indicator should be illuminated if the unit is operating normally.

RED LED: If a problem develops with the internal monitoring circuitry or, in the unlikely event that there should be a loss or reduction in the protection elements, the RED LED over the words "SYSTEM FAULT" will illuminate.

YELLOW LED: If the Yellow LED illuminates, at any time, there could be a hazardous system wiring fault. The YELLOW LED does not indicate a suppressor failure; however, it does signal that there maybe dangerous Neutral to Ground Voltages present. Consult with a qualified electrician to verify the integrity of the installation's wiring. (Not present on Delta Configurations.)

AUDIBLE ALARM: The Alarm will sound if protection should be lost on either the L-N or L-G Modes. Control of the Alarm is managed with a switch located on the front panel next to the Alarm. The switch has three (3) settings: Up (momentary only) for testing, which will sound the alarm. Center, this is the Disable position and turns the Alarm off. Down, this Enables the Alarm and sets it for constant monitoring.

OPTIONAL COUNTER: The Optional Surge Counter will show the number of transient events that the suppressor encounters. Control of the Surge Counter is managed with a switch located to the left of the counter display. The switch has three (3) settings: Up, (momentary only) for RESET. Center, this is the ENABLE position and turns the Counter on and sets it for constant monitoring. Down, (momentary only) this tests the Counter and will increase the count by 1 increment each time it is activated.