

INSTALLATION INSTRUCTIONS FOR:

MAPXXX/125-3W	3 Phase Wye, 4 Wire + Gnd
MAPXXX/220-3W	3 Phase Wye, 4 Wire + Gnd
MAPXXX/230-3W	3 Phase Wye, 4 Wire + Gnd
MAPXXX/240-3W	3 Phase Wye, 4 Wire + Gnd
MAPXXX/125-3H	High Leg Delta 4 Wire + Gnd
MAPXXX/240-3D	3 Phase Delta, 3 Wire + Gnd
MAPXXX/277-3W	3 Phase Wye, 4 Wire + Gnd
MAPXXX/480-3D	3 Phase Delta, 3 Wire + Gnd

ALL MAP MODELS MUST BE INSTALLED INSIDE AN APPROPRIATE NEMA APPROVED ENCLOSURE.

- 1) MAP Series products can be directly connected across the load side of the meter can or at the line side of the main breaker. A 30 or 60 amp disconnect may be used for ease of maintenance.
- 2) MAP Series products may be fed from the line side of a distribution panel or via a 20Amp or 30Amp circuit breaker in a distribution panel for ease of maintenance.
- 3) Optimize device performance by keeping connecting wires as short and as straight as possible. Plan the wiring path(s) prior to commencing any installation procedure. This will assist in keeping the wire lengths and inductance to a minimum.

IF POSSIBLE, SECURE ALL POWER FROM THE PANEL TO WHICH THE DEVICE IS BEING INSTALLED.

Mount the SPD using the two (2) mounting holes on the enclosure.

ENSURE ALL CONNECTIONS ARE CORRECT AND SECURE BEFORE ENERGIZING SPD.

UNIT DIAGNOSTICS

PHASE LED: When the SPD is securely connected and operating properly, the RED LED will be illuminated. Replacement of the SPD is required if the RED LED is not illuminated.

MAINTENANCE:

Check the status of the LED indicator at intervals not to exceed 2 months. If the LED Indicator is not illuminated the SPD requires replacement.

PLEASE NOTE: THERE ARE NO USER SERVICEABLE PARTS INSIDE.

WARRANTY INFORMATION

Meter-Treater, Inc. (MTI) warrants all MAP Series models to be free from defects, and will at our option repair or replace the product should it fail within ten (10) years from the first date of shipment. This warranty is limited to defects in workmanship or materials, and does not cover customer damage, abuse or unauthorized modification. If this product fails or does not perform as warranted, your sole recourse shall be repair or replacement as described above. Under no condition shall MTI be liable for any damages incurred by the use of this product. Damages include, but are not limited to, the following: lost profits, lost savings and incidental or consequential damages arising from the use of or inability to use this product. MTI specifically disclaims all other warranties, expressed or implied, and the installation or use of this product shall be deemed an acceptance of these terms by the user.

WARRANTY RETURNS

All warranty and non-warranty repairs must be returned freight prepaid and insured to **MTI**. All returns must have a Return Authorization (RA) number on the outside of the shipping container. This number may be obtained from **MTI** Warranty Department (800) 342-6890. Products returned without an RA number will not be accepted.

NOTE

IF UNIT(S) ARE RECEIVED DAMAGED,
NOTIFY THE SHIPPING COMPANY IMMEDIATELY.
RETAIN ALL SHIPPING CONTAINERS AND PACKING
MATERIALS FOR INSPECTION.

PRODUCT INFORMATION

MODEL #: _____

SERIAL #: _____

MANUFACTURED DATE: _____

QA Sign Off: _____

Meter-Treater, Inc.
1349 South Killian Drive, Lake Park, Florida 33403
Phone: (561) 845-2007 Fax: (561) 848-2372
e-mail: sales@metertreater.com
Website: www.metertreater.com

MAP Series Hardwire Device



**SURGE PROTECTION DEVICES
FOR
AC POWER APPLICATIONS**

THREE PHASE USER MANUAL AND INSTALLATION GUIDE



The MAP is a Type 4 Device for use in Type 1 or Type 2 environments. (IEEE Category C). The MAP Series is built to both UL's OWHX (Secondary Surges Arrestor) and 1449 Third Edition SPD standards....

P/N: ###-####-###
MS 234-03/21/2008-B



GENERAL

- A) This document provides detailed information on how to install and operate the **MAP Series** of Surge Protective Devices (SPD).
- B) Locate a position to mount the SPD inside a NEMA enclosure that will minimize the length of connecting wires required. The SPD should be as close a possible to the input power to the enclosure. Mount the units using the mounting holes provided as shown by the illustrations in these instructions.
- C) The **MAP Series** of SPDs are installed and connected in parallel ("shunt") across the AC supply to be protected. Connecting wires do not carry the supply current, only the short duration currents associated with the suppression of a transient event.
- D) Identified or indicated Leads/Wires must be connected exactly with respect to the AC Power feeding the SPD. Failure to do so may result in damage to the device or pose a danger to personnel.
- E) Incorrect installation may significantly impair the performance of the SPD. It is particularly important that all installation procedures and guidelines be followed exactly.
- F) **INSTALLATION OF THIS DEVICE SHOULD ONLY BE PERFORMED BY A QUALIFIED INSTALLER.**
- G) BEFORE STARTING ANY INSTALLATION PROCEDURES, VERIFY SERVICE VOLTAGES WITH AN AC VOLT-METER TO ENSURE THAT THE CORRECT SPD MODEL HAS BEEN SELECTED.
- H) CHECK TO ENSURE THAT ALL CONNECTIONS ARE CORRECT AND SECURE BEFORE ENERGIZING.
- I) KEEP THIS MANUAL IN A SAFE DRY PLACE FOR FUTURE REFERENCE.

FOR ASSISTANCE

CONTACT **M-TI** CUSTOMER SERVICE
AT 1-800-638-3788

MOUNTING INFORMATION

NOTE: Before starting any installation, measure the line voltages with an AC Voltmeter to ensure the correct device has been selected for the application.

RED LED IS A FUNCTIONALITY/POWER INDICATOR

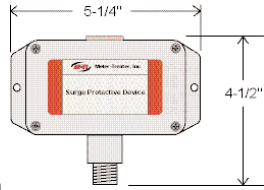

OPTIONAL:
1/2" Nipple Shown

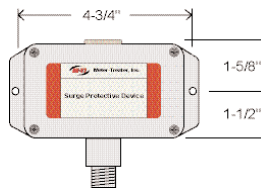

Mount the MAP SERIES SPD using the two mounting holes as close as possible to the connection point in the NEMA enclosure. Keeping the lead length short will increase the performance of the unit.

IF YOU CHOOSE TO MOUNT THE MAP UNIT, OBSERVE ALL SAFETY PROCEDURES APPLICABLE FOR A LIVE METER SOCKET OR ELECTRICAL PANEL.

Connecting conduit (if used) should be rated for use in the environment that the SPD NEMA enclosure is mounted.

Splicing wires to gain extra lead length is not advisable as the extra lead length will degrade the performance of the device.

WORKING NEAR EXPOSED LIVE CONDUCTORS IS HAZARDOUS. POWER SHOULD BE SECURED OR APPROPRIATE ELECTRICAL SAFETY EQUIPMENT SHOULD BE USED TO THE GREATEST EXTENT POSSIBLE BEFORE CONNECTING.

120/240VAC, High Leg Delta, 4 Wire + Ground
120/208VAC, Three Phase Wye, 4 Wire + Ground
277/480VAC, Three Phase Wye, 4 Wire + Ground

1. Deenergize as much as possible prior to installation.
2. Locate the mounting position of the SPD as close as possible to the electrical connection point. The SPD may be connected directly to the load side of the meter socket via spare/additional lugs or through a disconnect, fuse or circuit breaker rated not less than 20 amps.
3. Prepare any supplementary conduit, enclosures, or other materials for wire routing. Minimize right angles as they will degrade overall SPD performance.
4. Mount the device in your predetermined location inside the panel or equipment to be protected.
5. If present, connect the Green Ground wire to the system ground.
6. Connect the White Neutral wire to the neutral. Where neutral and ground are bonded (service entrance) and the SPD is equipped with a white neutral wire, the white neutral wire from the SPD should be connected to the same point as the ground.
7. If applicable, for high leg delta systems, connect the orange wire to the high leg phase.
CONNECTING A BLACK WIRE TO THE HIGH LEG OF A HIGH LEG DELTA WILL DAMAGE THE SPD.
8. Connect the Black Phase wires to each phase.
9. Energize the circuit if applicable. Check that the LED light is on.

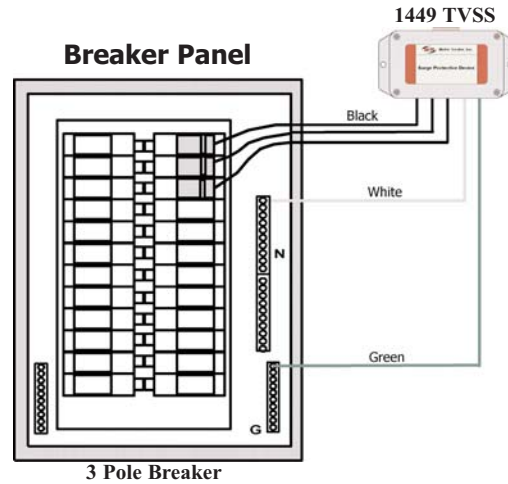

Example of connection to a 120/208V, 120/240V or 277/480V 3-Phase distribution panel
 MAP050/120-3Y-0-2
 MAP050/120-3H-0-2
 MAP050/277-3W-0-2

120 Volt AC	240 Volt AC	277 Volt AC
-------------	-------------	-------------

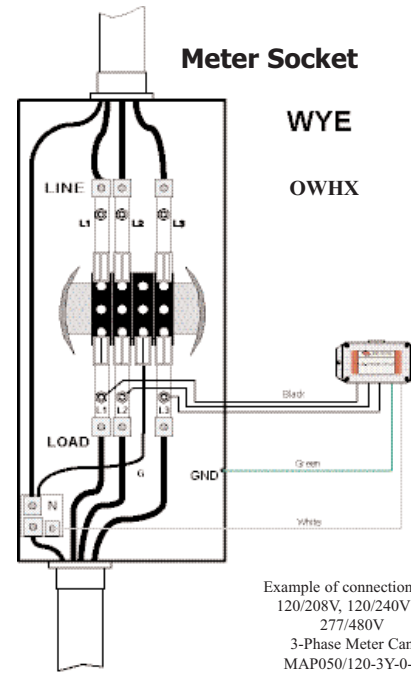
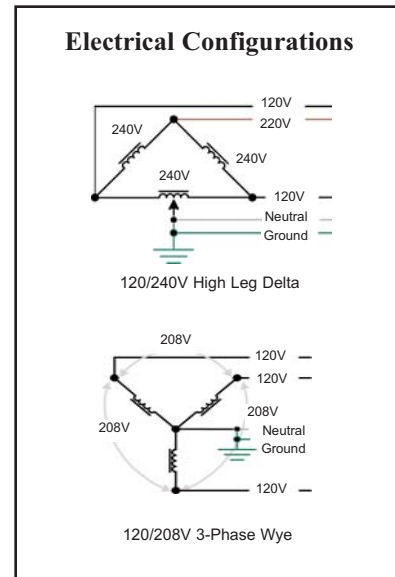

Example of connection to a 120/208V, 120/240V or 277/480V 3-Phase Meter Can
 MAP050/120-3Y-0-2
 MAP050/120-HL-0-2
 MAP050/277-3Y-0-2

240VAC, Three Phase Delta, 3 Wire + Ground
480VAC, Three Phase Delta, 3 Wire + Ground

1. Deenergize as much as possible prior to installation.
2. Locate the mounting position of the SPD as close as possible to the electrical connection point. The SPD may be connected directly to the load side of the meter socket via spare/additional lugs or through a disconnect, fuse or circuit breaker rated not less than 20 amps.
3. Prepare any supplementary conduit, enclosures, or other materials for wire routing. Minimize right angles as they will degrade overall SPD performance.
4. Mount the device in your predetermined location inside the panel or equipment to be protected.
5. If present, connect the Green Ground wire to the system ground.
6. Connect the Black Phase wires to each phase.
7. Energize the circuit if applicable. Check that the LED light is on.

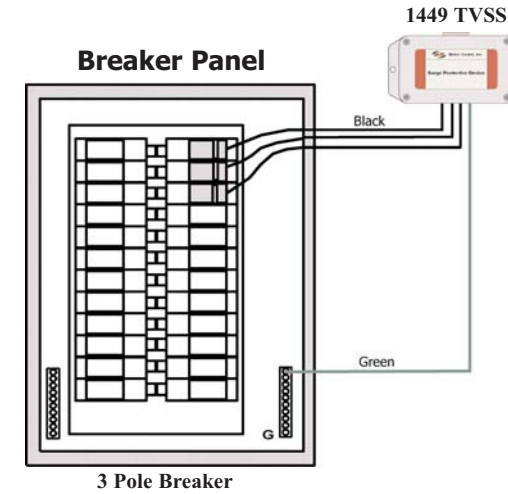

Example of connection to a 240V or 480V 3-Phase distribution panel
 MAP050/240-3D-0-1
 MAP050/480-3D-0-1

240 Volt AC	480 Volt AC
-------------	-------------

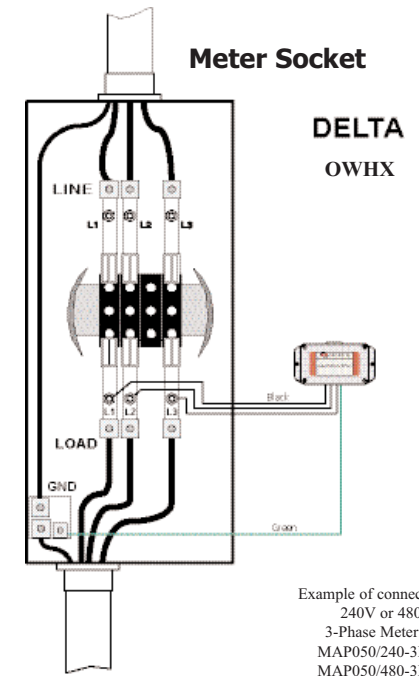
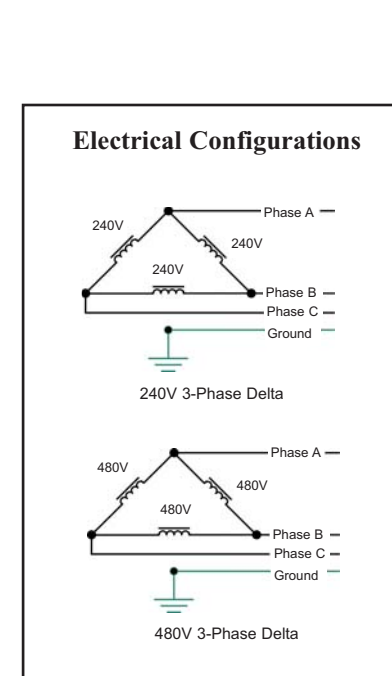

Example of connection to a 240V or 480V 3-Phase Meter Can
 MAP050/240-3D-0-1
 MAP050/480-3D-0-1