

WARRANTY INFORMATION

Meter-Treater, Inc. (M-Ti) warrants to its customers that the hardware products that M-Ti manufactures and sells will be free from defects in material and workmanship. Warranty coverage is for fifteen (15) years from the date of the original shipment from M-Ti. If any such product proves defective during the applicable warranty period, M-Ti, at its discretion, will repair without charge for parts and labor or will provide a replacement in exchange for the defective product.

This warranty shall not apply to any defect, failure, and/or damage caused by improper use, or inadequate maintenance or care. M-Ti shall not be obligated to furnish service under this warranty (a) to repair damage resulting from connection to incompatible equipment; or (b) to service a product that has been modified, altered or integrated with other products.

WARRANTY RETURNS

All warranty and non-warranty repairs must be returned freight prepaid and insured to **MTI**. All returns must have a Return Materials Authorization (RMA) number on the outside of the shipping container. This number may be obtained from **MTI** Customer Service at (800) 342-6890.

Products returned without an RMA number will not be accepted.

NOTE

IF UNIT(S) ARE RECEIVED DAMAGED, NOTIFY THE SHIPPING COMPANY IMMEDIATELY. RETAIN ALL SHIPPING CONTAINERS AND PACKING MATERIALS FOR INSPECTION.

Meter-Treater, Inc.
1349 South Killian Drive, Lake Park, Florida 33403
Phone: (561) 845-2007 Fax: (561) 848-2372
E-mail: sales@metertreater.com
Website: www.metertreater.com

MPT Series Surge Protective Device

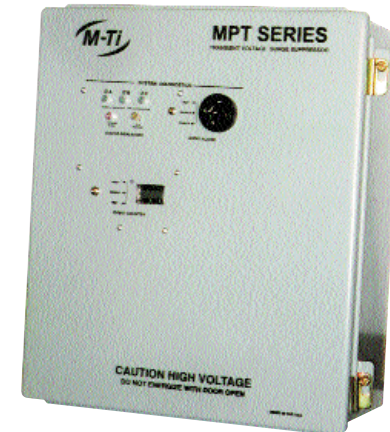

**SURGE PROTECTIVE DEVICES
FOR
AC POWER APPLICATIONS**

COMMERCIAL INSTALLATIONS

**USER MANUAL
AND
INSTALLATION GUIDE**

P/N: 904-4000-000
MS-198-07/28/10

GENERAL

- A.) This document provides detailed information on how to install and operate the **MPT Series** of Surge Protective Devices (SPD).
- B.) Units should be mounted as close as possible to the AC panel to be protected. It is recommended that conduit, preferably metallic, be utilized to accomplish this connection.
- C.) The MPT Series of Protectors are installed and connected in parallel ("shunt") across the AC supply to be protected. Connecting wires do not carry the supply current, only the short duration currents associated with the suppression of a transient event.
- D.) Identified or indicated terminals must be connected exactly with respect to the AC Power feeding the SPD. Failure to do so may result in damage to the device or pose a danger to personnel.
- E.) Incorrect installation may significantly impair the performance of the Surge Protective Device. It is particularly important that all installation procedures and guidelines be followed exactly.
- F.) **INSTALLATION OF THIS DEVICE SHOULD ONLY BE PERFORMED BY A QUALIFIED LICENSED ELECTRICIAN.**
- G.) Before starting any installation procedures, verify service voltages with an AC Voltmeter to ensure that the correct SPD Model has been selected.
- H.) Do not connect without securing power from the distribution panel.
- I.) Check to ensure that all connections are correct and secure before energizing. Do not energize with door open.
- J.) Keep this manual in a safe dry place for future reference.

MOUNTING INFORMATION (ALL MPT MODELS)

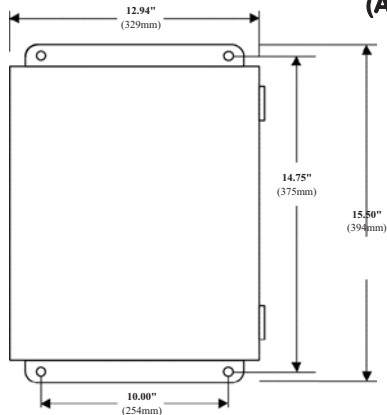

[Figure #1: MPT Front View]

After determining a position to mount the device, that will minimize the length of the connecting wires, drill a hole in the MPT for the conduit to run the wires from the distribution panel to the connecting lugs inside the SPD. Installation is simplified if the wires enter the enclosure at the top (see figure #2) of the enclosure. Securely mount the TVSS unit using 1/4-20 bolts in the four (4) mounting holes provided in the enclosure's mounting flanges.

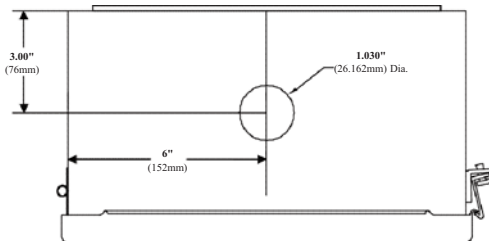

[Figure #2: MPT Top View]

CONSTRUCTION

14 Gauge steel with continuous hinge.
UL 50 Type 12 and Type 13.
NEMA/EEMAC Type 12 and Type 13.
JIC standard #GP-1-1967.
CSA Type 12.
IEC 529, IP65.

FINISH

ANSI 61 Gray polyester.
Powder coating inside and
out over phosphatized surfaces.

MAINTENANCE INSTRUCTIONS

At intervals not to exceed two (2) months check and verify:

1. Diagnostic and Indication display.
2. Alarm Operation
3. Condition of ALL Connection Cables and Terminations

INSTALLATION, SERVICE OR REMOVAL OF THIS DEVICE SHOULD ONLY BE PERFORMED BY A QUALIFIED LICENSED ELECTRICIAN.

ANY ALTERATIONS, TAMPERING, MISUSE OR UNAUTHORIZED REPAIRS OF THIS PRODUCT WILL VOID ITS ORIGINAL FACTORY WARRANTY.

IMPORTANT DATA

DATE PURCHASED: _____ **DATE INSTALLED:** _____

DEALER/DISTRIBUTOR'S NAME AND ADDRESS: _____

CONTACT(S): _____

PHONE #: _____ **FAX #:** _____

CONTRACTOR'S NAME AND ADDRESS: _____

PHONE #: _____ **FAX #:** _____

PRODUCT INFORMATION

MODEL #: _____ **SERIAL #:** _____

MANUFACTURED DATE: _____

INTERNAL LAYOUT

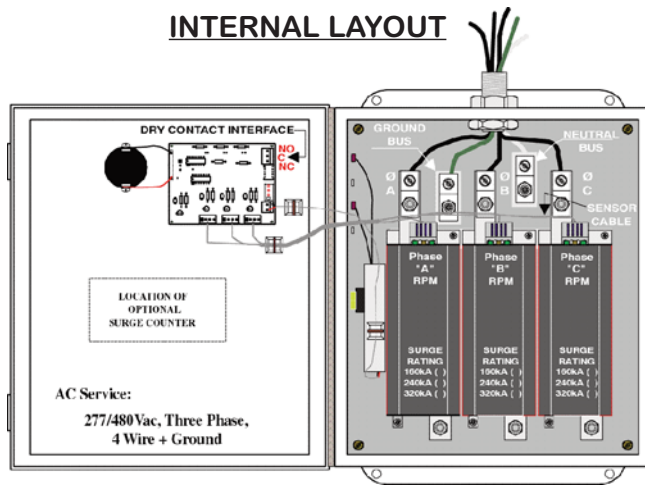

[Figure #11: Internal Layout]

THERE ARE NO USER SERVICEABLE PARTS INSIDE MAIN HOUSING

MPT (100/200/300) Models:

The specific product you have in service may be configured for any one of the following kA ratings: (100=100kA/Phase) (200=200kA/Phase) and (300=300kA/Phase).

AC Service(s)

120 or 240Vac, Single Phase	277/480Vac, 3 Phase Wye
120/240Vac, Split Phase	220/380Vac, 3 Phase Wye
240 or 480Vac, Three Phase Delta	230/400Vac, 3 Phase Wye
120/240Vac, Three Phase Delta (High Leg)	240/415Vac, 3 Phase Wye
120/208Vac, 3 Phase Wye	

The MPT Series utilize the RPM Series of Replaceable Protection Modules.

RPM REMOVAL & REPLACEMENT

1. Make Sure the power has been turned off to the MPT unit. Never work on the SPD unit while energized.
2. Disconnect the Sensor Cable from the RPM module. (Ø Side End Cap)
3. Remove the 1/4 20 bolts securing the RPM module to the phase and neutral tabs. One bolt at each end of the module. The compression lug comes off also.
4. Remove the 2 #6 Screws (1 at each end of the unit) securing the RPM to the Back Plane PC Board.
5. Remove the module from the MPT unit.
6. To mount the replacement module reverse steps 4, 3 and 2. Do not forget to reinstall the compression lug.
7. Close the MPT door and reconnect power.

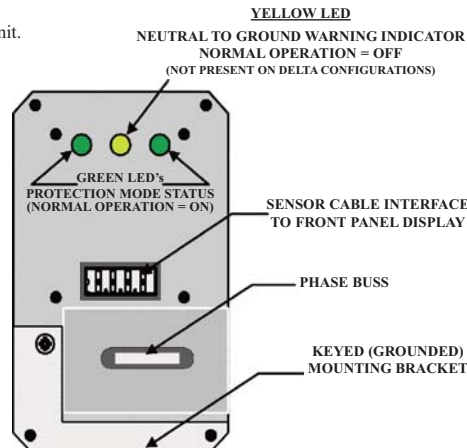

[Figure #12: RPM Ø Side End Cap]

INSTALLATION INSTRUCTIONS

Before starting the installation, measure the Line voltage with an AC voltmeter to ensure the correct device has been selected for the current application. The MCOV (maximum continuous operating voltage) **Cannot** exceed the maximum limits for the following service voltages:

120VAC=150MCOV	240VAC=320MCOV
220VAC=320MCOV	277VAC=320MCOV
230VAC=320MCOV	480VAC=550MCOV

STANDARD ELECTRICAL CONFIGURATIONS

120 or 240Vac, Single Phase, 2 Wire + Ground

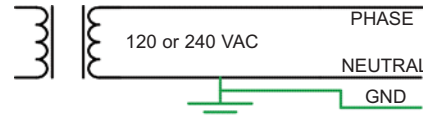

Requires a 1 Pole Breaker

[Figure #3]

120/240Vac, Split Phase, 3 Wire + Ground

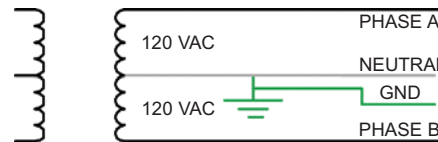

Requires a 2 Pole Breaker

[Figure #4]

240 or 480Vac, Three Phase Delta, 3 Wire + Ground

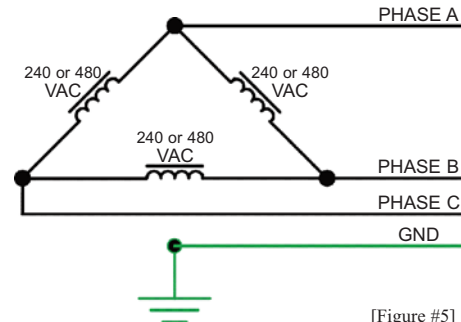

Requires a 3 Pole Breaker

[Figure #5]

120/240Vac, Three Phase Delta, 4 Wire + Ground

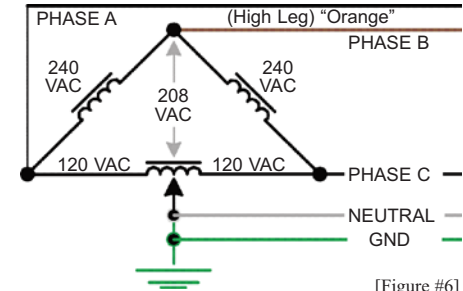

Requires a 3 Pole Breaker

[Figure #6]

120/208Vac, Three Phase Wye, 4 Wire + Ground

OR
277/480Vac, Three Phase Wye, 4 Wire + Ground

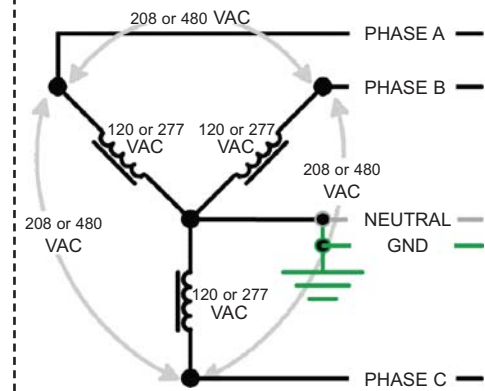

Requires a 3 Pole Breaker

[Figure #7]

NOTE

Wye Configuration is applicable for:

- 220/380VAC
- 230/400VAC
- 240/415VAC

CAUTION:

BEFORE ENERGIZING THE SPD:
ENSURE ALL CONNECTIONS ARE CORRECT.
DO NOT ENERGIZE WITH FRONT COVER OPEN.

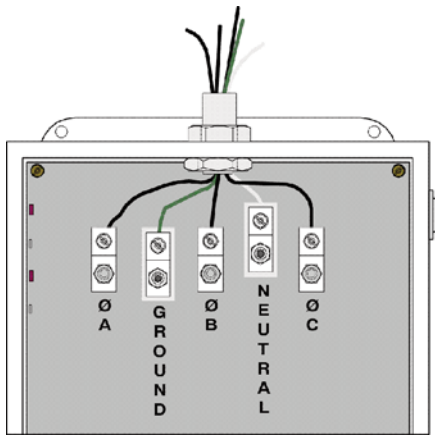

[Figure #9: 3 Phase Wye Wire Hook-up]

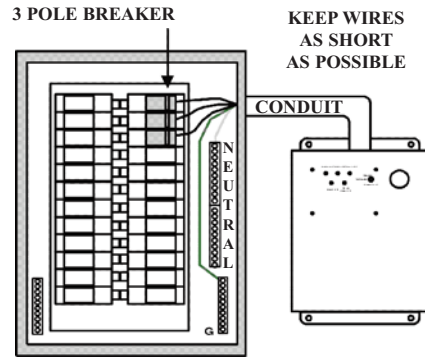

[Figure #8: 3 Phase Wye Breaker Hook-up]

NOTES:

- 1) For Single Phase Models, Phase "A" & Phase "C" lines are left vacant.
- 2) For Split Phase Models, Phase "B" is left vacant.
- 3) For Delta Configurations, the Neutral position is left vacant.

1. CONNECT THE GROUND WIRE TO THE SERVICE PANEL GROUND BUS.
2. CONNECT THE NEUTRAL WIRE FROM THE SERVICE PANEL NEUTRAL BUS TO THE LUG LABELED NEUTRAL. (Except for Delta Application)
3. CONNECT THE PHASE (HOT) WIRES FROM A 3 POLE BREAKER TO THE SPD DEVICE CONNECTORS LABELED PHASE "A", "B" AND "C", as appropriate.

FRONT PANEL DIAGNOSTICS

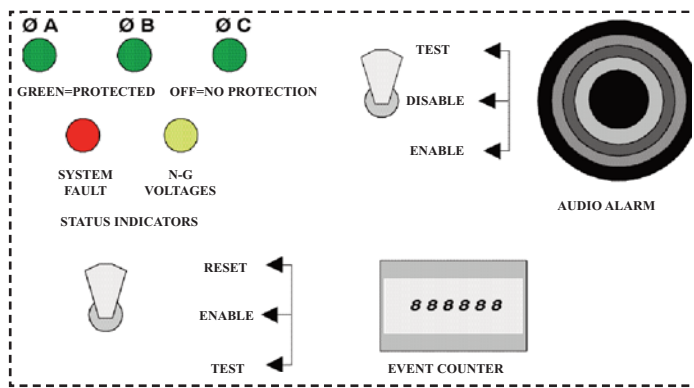

[Figure #10: 3 Phase Wye Configuration Shown]

NOTES:

- 1) For Single Phase Models: Only 1 Green LED, in the Phase "B" position, is provided.
- 2) For Split Phase Models: 2 Green LEDs, in Phase "A" & "C" positions, are provided.
- 3) For Delta Models: There is no Yellow, N-G, LED.

STATUS INDICATORS

GREEN LEDs: When the SPD is securely connected and operating properly, the GREEN LEDs, under the heading "PHASE INDICATORS", will be illuminated. No other indicator should be illuminated if the unit is operating normally.

RED LED: If a problem develops with the internal monitoring circuitry or, in the unlikely event that there should be a loss or reduction in the protection elements, the RED LED over the words "SYSTEM FAULT" will illuminate.

YELLOW LED: If the Yellow LED illuminates, at any time, there could be a hazardous system wiring fault. The YELLOW LED does not indicate a suppressor failure; however, it does signal that there maybe dangerous Neutral to Ground Voltages present. Consult with a qualified electrician to verify the integrity of the installation's wiring. (Not present on Delta Configurations.)

AUDIBLE ALARM: The Alarm will sound if protection should be lost on either the L-N or L-G Modes. Control of the Alarm is managed with a switch located on the front panel next to the Alarm. The switch has three (3) settings: Up (momentary only) for testing, which will sound the alarm. Center, this is the Disable position and turns the Alarm off. Down, this Enables the Alarm and sets it for constant monitoring.

OPTIONAL COUNTER: The Optional Surge Counter will show the number of transient events that the suppressor encounters. Control of the Surge Counter is managed with a switch located to the left of the counter display. The switch has three (3) settings: Up, (momentary only) for RESET. Center, this is the ENABLE position and turns the Counter on and sets it for constant monitoring. Down, (momentary only) this tests the Counter and will increase the count by 1 increment each time it is activated.

TROUBLE SHOOTING GUIDE

There is little or no trouble shooting required for this Series of products. However, there are situations where there could arise a scenario where the Front Panel Diagnostics does not operate as intended. In such a case follow these directions...

PROBLEM:

No Front Panel Diagnostics or improper operation:

Ensure that SPD unit is properly connected to the AC Service Panel and that all connections are secure.

Confirm that the breaker in the AC supply panel is in the ON position.

If problem still persists: TURN OFF BREAKER, open the SPD door and verify that all VISIBLE cable connections are properly secured, no loose wires. This is especially critical for the connectors on the Sensor Cable as they interface with the RPM modules. When RPM is properly connected the 2 Green LEDs should be illuminated and the center Yellow LED (not applicable on Delta Units) should not. DO NOT attempt to trouble shoot inside individual RPM Modules.

In the unlikely event that these measures have failed to correct the problem contact your dealer or the factory for additional information.